



2SA928A

PNP SILICON TRANSISTOR

AUDIO POWER AMPLIFIER

■ FEATURES

- * Collector Dissipation $P_C=1$ W
- * 3 W Output Application
- * Complement of 2SC2328A

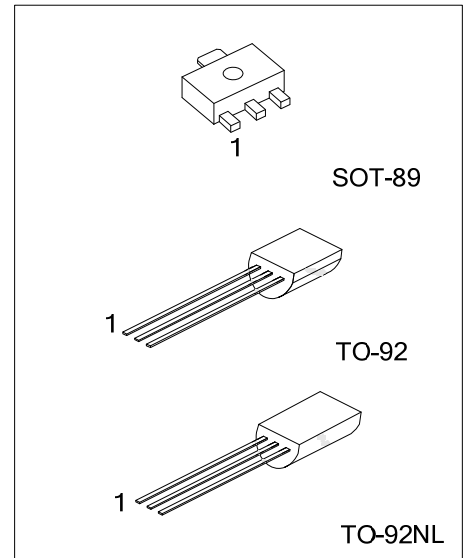

■ ORDERING INFORMATION

Ordering Number		Package	Pin Assignment			Packing
Lead Free	Halogen Free		1	2	3	
-	2SA928AG-AB3-R	SOT-89	B	C	E	Tape Reel
2SA928AL-x-T92-B	2SA928AG-x-T92-B	TO-92	E	C	B	Tape Box
2SA928AL-x-T92-K	2SA928AG-x-T92-K	TO-92	E	C	B	Bulk
2SA928AL-x-T9N-B	2SA928AG-x-T9N-B	TO-92NL	E	C	B	Tape Box
2SA928AL-x-T9N-K	2SA928AG-x-T9N-K	TO-92NL	E	C	B	Bulk

<p>2SA928AG-x-AB3-R</p> <p>(1) Packing Type (2) Package Type (3) Rank (4) Lead Plating</p>	<p>(1) R: Tape Reel, B: Tape Box, K: Bulk (2) AB3: SOT-89, T92: TO-92, T9N: TO-92NL (3) x: refer to Classification of h_{FE} (4) G: Halogen Free, L: Lead Free, Blank: Pb/Sn</p>
--	---

■ MARKING

SOT-89	TO-92	TO-92NL

■ ABSOLUTE MAXIMUM RATINGS ($T_A=25^\circ\text{C}$, unless otherwise specified)

PARAMETER		SYMBOL	RATINGS	UNIT
Collector- Base Voltage		V_{CBO}	-30	V
Collector-Emitter Voltage		V_{CEO}	-30	V
Emitter-Base Voltage		V_{EBO}	-5	V
Collector Current		I_C	-2	A
Collector Dissipation	SOT-89	P_C	0.5	W
	TO-92/TO-92NL		1.0	W
Junction Temperature		T_J	+150	$^\circ\text{C}$
Storage Temperature		T_{STG}	-55 ~ +150	$^\circ\text{C}$

Note: Absolute maximum ratings are those values beyond which the device could be permanently damaged. Absolute maximum ratings are stress ratings only and functional device operation is not implied.

■ ELECTRICAL CHARACTERISTICS ($T_A=25^\circ\text{C}$, unless otherwise specified)

PARAMETER	SYMBOL	TEST CONDITIONS	MIN	TYP	MAX	UNIT
Collector-Base Breakdown Voltage	BV_{CBO}	$I_C = -100\mu\text{A}$, $I_E = 0$	-30			V
Collector-Emitter Breakdown Voltage	BV_{CEO}	$I_C = -1\text{mA}$, $I_B = 0$	-30			V
Emitter-Base Breakdown Voltage	BV_{EBO}	$I_E = -1\text{mA}$, $I_C = 0$	-5			V
Collect Cut-off Current	I_{CBO}	$V_{CB} = -30\text{V}$, $I_E = 0$			-100	nA
Emitter Cut-off Current	I_{EBO}	$V_{BE} = -5\text{V}$, $I_C = 0$			-100	nA
DC Current Ratio	h_{FE}	$V_{CE} = -2\text{V}$, $I_C = -500\text{mA}$	100		320	
Base-Emitter on Voltage	$V_{BE(ON)}$	$V_{CE} = -2\text{V}$, $I_C = -500\text{mA}$			-1	V
Collector-Emitter Saturation Voltage	$V_{CE(SAT)}$	$I_C = -1.5\text{A}$, $I_B = -30\text{mA}$			-2	V
Output Capacitance	C_{OB}	$V_{CB} = -10\text{V}$, $I_E = 0$, $f = 1\text{MHz}$		48		pF
Current Gain Bandwidth Product	f_T	$V_{CE} = -2\text{V}$, $I_C = -500\text{mA}$		120		MHz

■ CLASSIFICATION OF h_{FE}

RANK	Q	Y
RANGE	100 ~ 200	160 ~ 320

TYPICAL CHARACTERISTICS

